

Model GD-30S

PRESSURE REDUCING VALVE

Installation & Operation Manual

Please read this bulletin thoroughly before using the pressure reducing valve, so that you may do so correctly and safely. Please carefully store this bulletin in a handy place.

-----The following safety symbols are used in this manual.-----

 **Warning**

This symbol indicates a potentially hazardous situation that, if not avoided, could result in death or serious injury.

 **Caution**

This symbol indicates a hazardous situation that, if not avoided, may result in minor or moderate injury. ("Caution" may also be used to indicate other unsafe practices or risks of property damage.)

Contents

1. Specifications	1
2. Dimensions and Weights	1
3. Operation	2
4. Nominal Size Selection Chart.....	3
5. Installation	
5.1 Example of piping	4
5.2 Precautions during installation	4
6. Operating Procedure	
6.1 Precautions during operation	5
6.2 Adjustment procedures	5
7. Maintenance Procedure	
7.1 Troubleshooting.....	6
7.2 Precautions during maintenance and inspection	6
7.3 Disassembly procedure.....	6
7.4 Exploded drawing	7
Warranty Information	

YOSHITAKE

1. Specifications

Model	GD-30S		
Size	15A, 20A, 25A		
Fluid	Steam		
Connection	JIS Rc Screwed, NPT Screwed, BSPT Screwed		
Inlet Pressure	2.0 MPa or less		
Reduced Pressure	Type	Spring Color	Setting Pressure range
	A Spring	Yellow	0.02~0.1MPa
	B Spring	Blue	0.05~0.4 MPa
C Spring	Yellow-green	0.35~1.0 MPa	
Minimum differential Pressure	0.05 MPa		
Max. pressure reducing ratio	10:1		
Max. Temperature	220 °C		
Valve Seat Leakage	Rated leakage is 0.1% or less of rated flow		
Material	Body	Stainless Steel	
	Cap	Stainless Steel	
	Bellows	Stainless Steel	
	Spring Chamber	Aluminium	
	Valve	Stainless Steel	
	Valve Seat	Stainless Steel	

Caution

Please collate with attached nameplate and specification of ordered model.
 * Please consult factory in case they do not match each other.

2. Dimensions and Weights

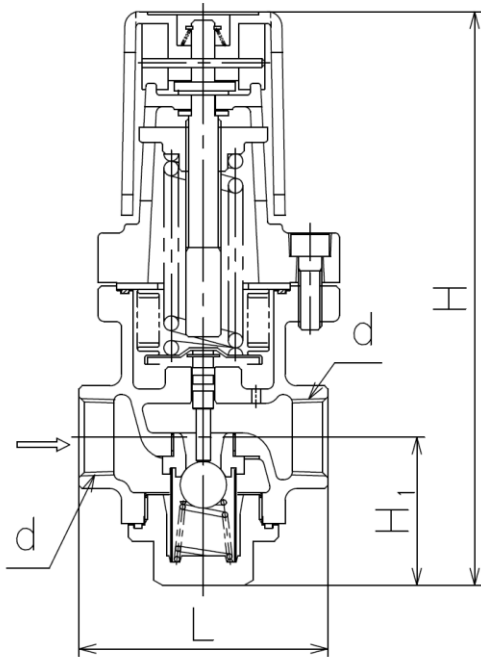

Nominal size	d	(mm)			Weight (kg)
		L	H ₁	H	
15A	Rc 1/2 NPT 1/2 BSPT 1/2	80	50.5	196	1.9
20A	Rc 3/4 NPT 3/4 BSPT 3/4	85	50.5	196	1.9
25A	Rc 1 NPT 1 BSPT 1	95	50.5	196	2.0

3. Operation

When the adjusting screw [11] connected to the handle [4] pushes the adjusting spring [12], the bellows [10] are extended and the spindle [8] opens the valve [7]. When the valve opens, the steam flowing to the outlet side passes through the reduced pressure detection hole, and becomes an upwardly directed pressure under the bellows and balances the force of the adjusting spring. The degree of valve opening is adjusted by the balancing of inlet and reduced pressures, there by stabilizing reduced pressure.

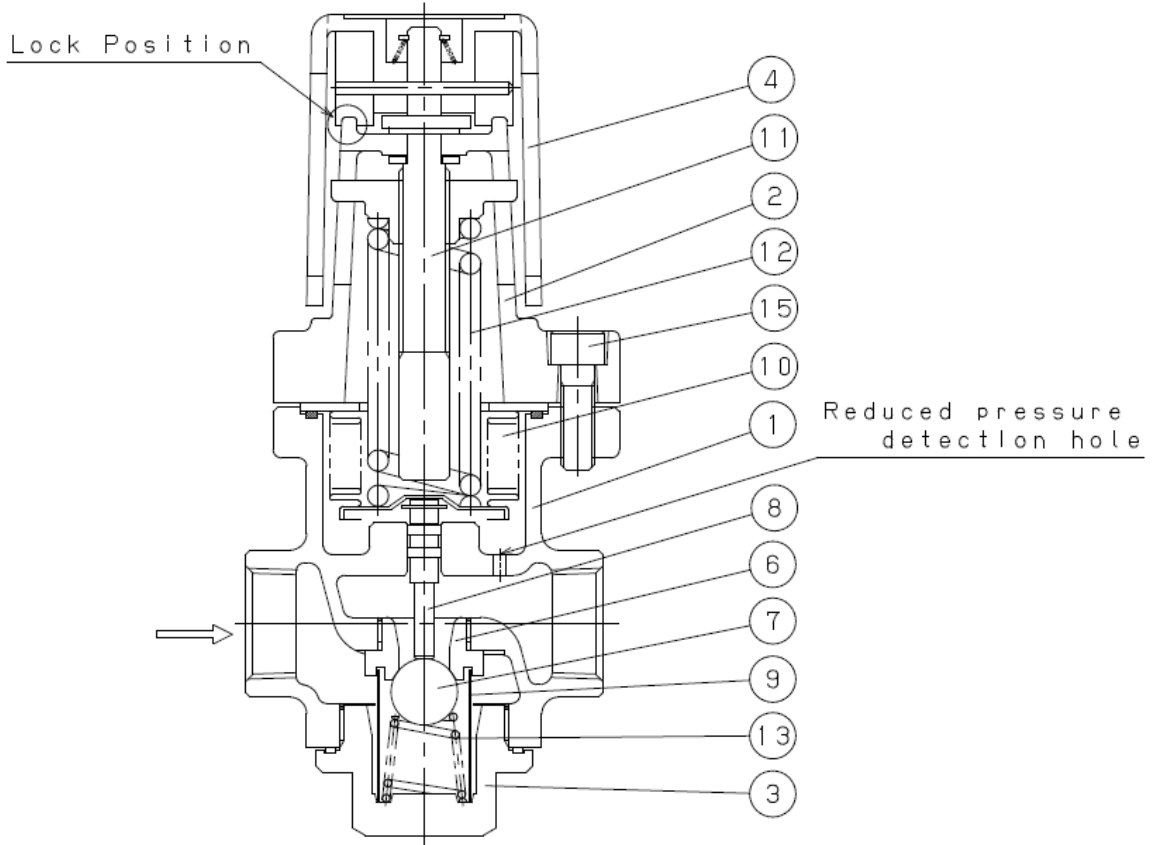

No.	Parts Name	No.	Parts Name
1	Body	9	Screen
2	Spring Chamber	10	Bellows
3	Cap	11	Adjusting Screw
4	Handle	12	Adjusting Spring
6	Valve Seat	13	Valve Spring
7	Valve	15	Bolts
8	Spindle		

4. Nominal Size Selection Chart

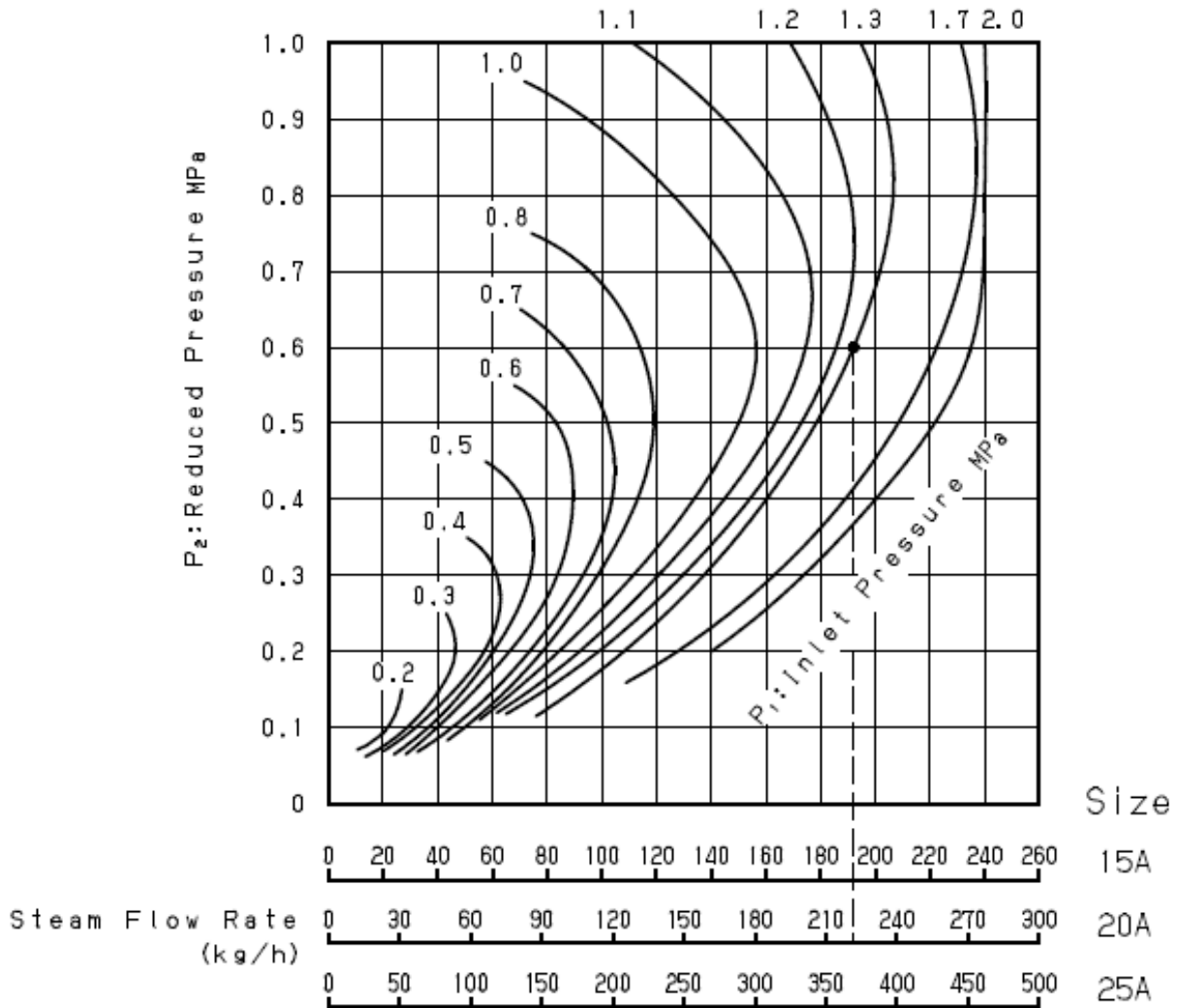

[Example]

Under the following operating conditions, the appropriate nominal size would be determined as described below.

Inlet pressure (P_1): 1.3 MPa

Reduced pressure (P_2): 0.6 MPa

Steam flow rate: 200 kg/h

First, find the point where the inlet and reduced pressures intersect. Next draw a line straight down from that point to the nominal size scale where a flow rate of 200 kg/h or more is indicated. The appropriate nominal size is indicated at the right side of the flow rate scale. For the above example, a nominal size of 20A should be selected.

5. Installation

5.1 Example of piping

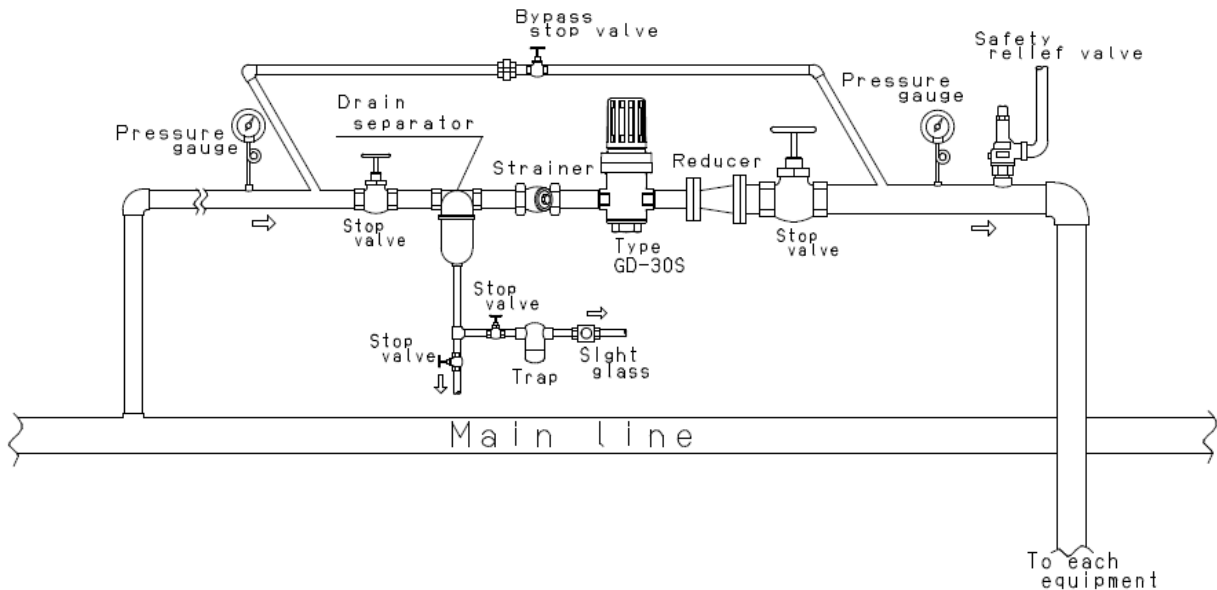

5.2 Precautions during installation

⚠ Warning

In case installing safety valve as safety device at outlet side, joint relief pipe at outlet of safety valve and guide it to safety place where steam can relief out.

* Failure to do so may result in burns.

⚠ Caution

- (1) Do not disassemble the valve unreasonably.
* Disassembling the valve at your discretion may affect the original performance.
- (2) Remove foreign matter and scales from the lines before connecting the valve.
* Failure to do so may result in the valve from functioning incorrectly.
- (3) Install a strainer (80 mesh) at the valve inlet side.
* Failure to do so may hamper correct pressure control, which affects the original performance.
- (4) Install a safety valve at the valve outlet sides as safety device for equipment.
* Failure to do so cannot identify PRV problem, resulting in equipment damage.
- (5) Install a pressure gauge at both the inlet and outlet sides of the valve.
* Failure to do so may hamper correct pressure adjustment.
- (6) Install a steam trap to the inlet sides of the valve to prevent drainage problems.
* Failure to do so may result in drainage problem, affecting the original performance.
- (7) When installing quick open and close valves, such as a solenoid valve, install it at inlet side as much as possible, and secure at least 3 m from the valve.
* Failure to do so may result in malfunction or drastically shortened service life.
- (8) When pressure reducing in two stages, secure at least 3 m between the valves.
* Failure to do so may result in malfunction, affecting the original performance.
- (9) Install the valve in proper direction of the fluid flow.
* Failure to do so may affect the original performance.
- (10) Do not apply excessive load, torque or vibration to the valve.
* Doing so may result in malfunction or drastically shortened service life.
- (11) Install the valve perpendicularly to horizontal lines.
- (12) Provide the by-pass line. (See 5.1 Example of piping)
- (13) Set pressure of safety relief valve should be higher than the pressure reducing valve's pressure.
- (14) When the reducing ratio is large, install a reducer to keep the flow velocity in the pipe 30 m/s.

6. Operating Procedure

6.1 Precautions during operation

Warning

- (1) Do not touch the valve directly with bare hands.
 - * Doing so may result in burns.
- (2) Before flow the steam in pipeline, make sure steam can flow without any dangerous at the end of pipeline and pipeline is connected tightly.
 - * In case steam blow off, it may result in burns.

Caution

- (1) Close the stop valves before and after the reducing valve, and remove all foreign matter and scales via the by-pass line before operation. And, open each stop valve slowly.
 - * Failure to do so may prevent the valve from functioning correctly. And, it may cause hunting, water hammer, etc., resulting in damage to the valve and other equipment when the stop valve is opened quickly.
- (2) When adjusting pressure, slowly turn the handle. Incorrect adjustment may cause hunting, water hammer, etc., it may result in damage to the valve and other equipment.
- (3) Remove fluid completely from the line, and close the stop valves before and after the valve when not using it for long periods of times.
 - * Rust generated in the valves and lines may cause malfunction.

6.2 Adjustment Procedure

Lift the handle to unlock. Then turn the handle in the direction of the (+) symbol on the name plate raises reduced pressure. Turning in the direction of the (-) symbol reduces pressure. The handle goes back to original position when your hand is released.

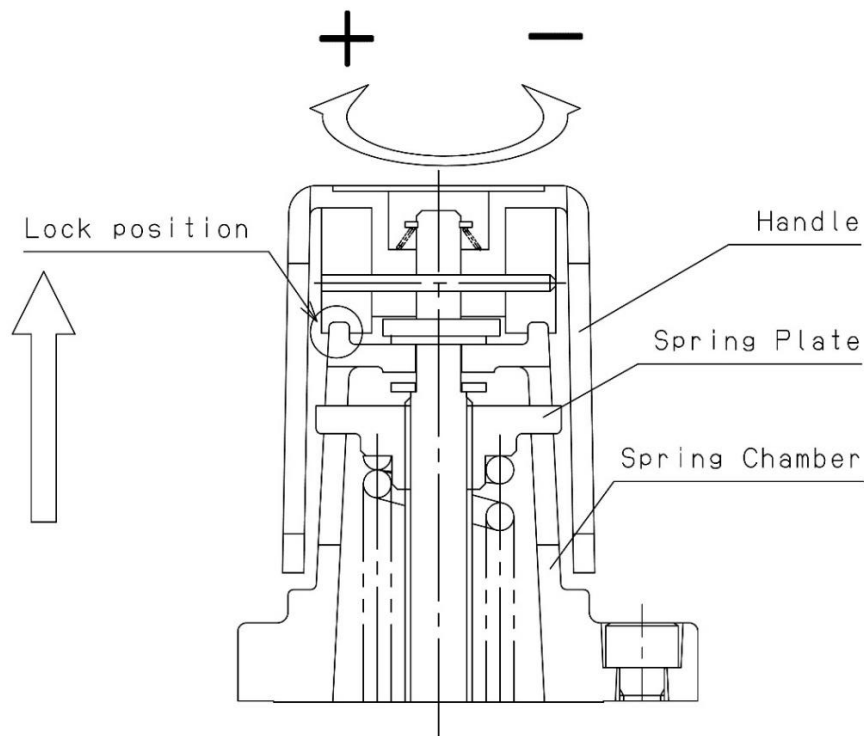

Caution

- (1) Excessive turning of the handle may damage the spring chamber. Be sure to turn the handle within the range where the spring plate and spring chamber do not come into contact with each other.
 - * If the spring chamber is damaged, the broken parts scatter due to the spring force, which may result in injury.
- (2) Use working gloves because there is a possibility that the handle gets heated.
 - * Doing so may result burns.

7. Maintenance Procedure

7.1 Troubleshooting

Problem	Cause	Solution
Pressure does not rise to the desired level.	<ol style="list-style-type: none"> 1. Incorrect pressure is being used. 2. Nominal size is too small for these specifications. 3. Incorrect adjustment. 4. Screen is clogged. 5. Pressure gauge malfunction. 	<ol style="list-style-type: none"> 1. Correct the pressure. 2. Replace with the correct nominal sized item. 3. Re-adjust according to the adjustment procedure. 4. Disassemble and clean. 6. Replace the pressure gauge.
Reduced pressure exceeds prescribed level.	<ol style="list-style-type: none"> 1. Foreign matter is embedded in the valve and/or valve seat, or else scratches exist. 2. Reduced pressure sensing hole is clogged with foreign matter. 3. By-pass valve is leaking. 	<ol style="list-style-type: none"> 1. Disassemble and clean. If scratches exist, polish them away. 2. Disassemble and clean. 3. Repair or replace the valve.
Abnormal noise is heard.	<ol style="list-style-type: none"> 1. Pressure reduction ratio is too large. 2. Drainage problem. 3. An abrupt open/close valve is located too close to the pressure reducing valve. 	<ol style="list-style-type: none"> 1. Use a two-stage reduction. 2. Install a trap. 3. Move distance as much as possible between the valves.

7.2 Precautions during maintenance and inspection

Warning

Completely discharge internal pressure from the valves, lines, and equipment, and cool the valve down to a level where you can touch it with bare hands before disassembly and inspection.

* Failure to do so may result in injury or burns due to residual pressure or spillage around the valve.

Caution

- (1) In order to maintain original performance and function, examine daily and personal inspection. And, periodical inspection must be examined according to the regulations of every kind.
 - * For general users, request to specialized in dealer or manufacture.
- (2) Pressure reducing valve shall be disassembled and inspected by qualified person or manufacture.
 - * Request the treatment to specialized dealer or manufacture in case of any problems.
- (3) While disassembly, drain flow out from the valve, so catch it by container. And release steam completely before disassembling.
 - * In case of no container for drain, it makes dirty surrounding the valve.
- (4) Close the stop valves before and after the reducing valve, and remove all foreign matter and scales via the by-pass line before operation.
 - * Failure to do so may result in the valve from functioning incorrectly.
- (5) In case of no operation for a long period of time, perform operating exam before start operation again.
 - * Request the treatment to specialized dealer or manufacture in case of any problems.

7.3 Disassembly procedure (Refer to "7.4 Exploded drawing")

- (1) Discharge the valve's internal pressure until a zero-pressure condition is established.
- (2) While lifting the handle [4], turn it in the Counter-Clock Wise direction (minus direction of nameplate at top of handle) until the adjusting spring [12] is free(no-load).
- (3) Unscrew the bolts [15] which secure the spring chamber [2] and remove the spring chamber (handle etc. cannot be disassembled), the adjusting spring, the bellows [10], and the spindle [8].
- (4) Remove the cap [3] by turning it in the Counter-Clock Wise direction then extract the valve spring [13], Screen [9], and valve [7] from the body [1].
- (5) Assemble in the reverse order of Disassembly. And tighten the bolts evenly. Assemble the valve due to the order. Failure to do so may lead to not assemble correctly. And if the hexagon bolts are not screwed correctly, it may cause steam leakage problem.

7.4 Exploded drawing

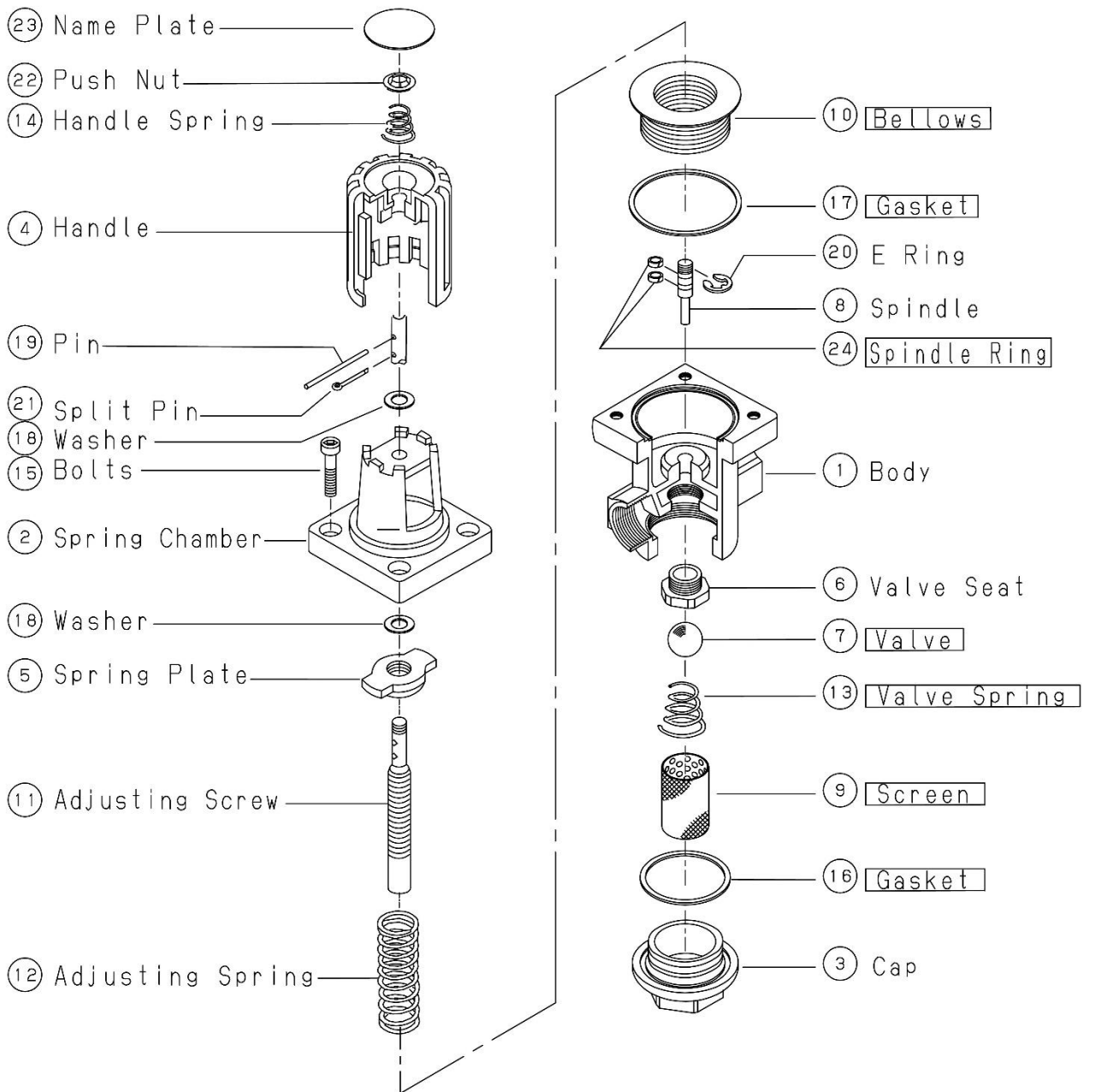

* Part names shown in boxes are consumable items.

Warranty Information

1. Limited warranty

This product has been manufactured using highly-advanced techniques and subjected to strict quality control. Please be sure to use the product in accordance with instructions on the manual and the label attached to it.

Yoshitake warrants the product to be free from any defects in material and workmanship under normal usage for a period of one year from the date of receipt by the original user, but no longer than 24 months from the date of shipment from Yoshitake's factory.

2. Parts supply after product discontinuation

This product may be subject to discontinuation or change for improvement without any prior notice. After the discontinuation of the product, Yoshitake supplies the repair parts for 5 years otherwise individually agreed.

3. This warranty does not cover the damage due to any of below:

- (1) Valve seat leakage or malfunction caused by foreign substances inside piping.
- (2) Improper handling or misuse.
- (3) Improper supply conditions such as abnormal water pressure/quality.
- (4) Water scale or freezing.
- (5) Trouble with power/air supply.
- (6) Any alteration made by other than Yoshitake.
- (7) Use under severe conditions deviating from the design specifications (e.g. in case of corrosion due to outdoor use).
- (8) Fire, flood, earthquake, thunder and other natural disasters.
- (9) Consumable parts such as O-ring, gasket, diaphragm and etc.

Yoshitake is not liable for any damage or loss caused by malfunction or defect of the product.