

# MS-6

## Noiseless Heater

### Instruction Manual

Thank you very much for purchasing our Noiseless Heater.  
Please read this instruction manual thoroughly before using the Noiseless Heater, so that you may do so correctly and safely. Please carefully store this manual in a handy place.

-----The following safety symbols are used in this manual.-----

#### **⚠ Warning**

This symbol indicates a potentially hazardous situation that, if not avoided, could result in death or serious injury.

#### **⚠ Caution**

This symbol indicates a hazardous situation that, if not avoided, may result in minor or moderate injury. ("Caution" may also be used to indicate other unsafe practices or risks of property damage.)

#### Contents

1. Specifications .....	1
2. Dimensions and weights .....	1
3. Nominal size selection method .....	2~3
4. Noise characteristics charts .....	3~4
5. Installation and operation	
5.1 Precaution for installation .....	5
5.2 Example of piping .....	5
5.3 Precaution for operation .....	5
After sales service	

# YOSHITAKE

## 1. Specifications

Fluid	Steam
Nominal size	15A-50A
Pressure range	0.05~0.7 MPa
Maximum warning sound temperature limit	90°C
Material	Stainless steel
Connection	JIS Rc screwed

## 2.2 Dimensions and weights

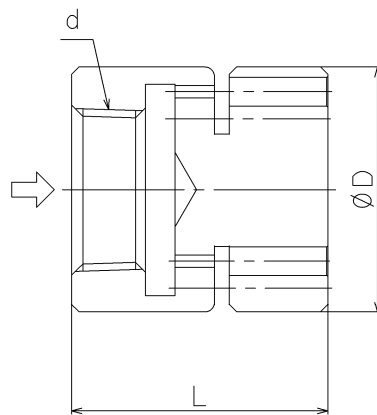

(mm)

Nominal size	d	L	D	Weight (kg)
15A	Rc1/2	48.5	35	0.25
20A	Rc3/4	49	44.5	0.40
25A	Rc1	52	50	0.52
32A	Rc1 1/4	55	60	0.77
40A	Rc1 1/2	59	70	1.15
50A	Rc2	65	105	2.99

### 3 Nominal size selection method

- Nominal size selection chart

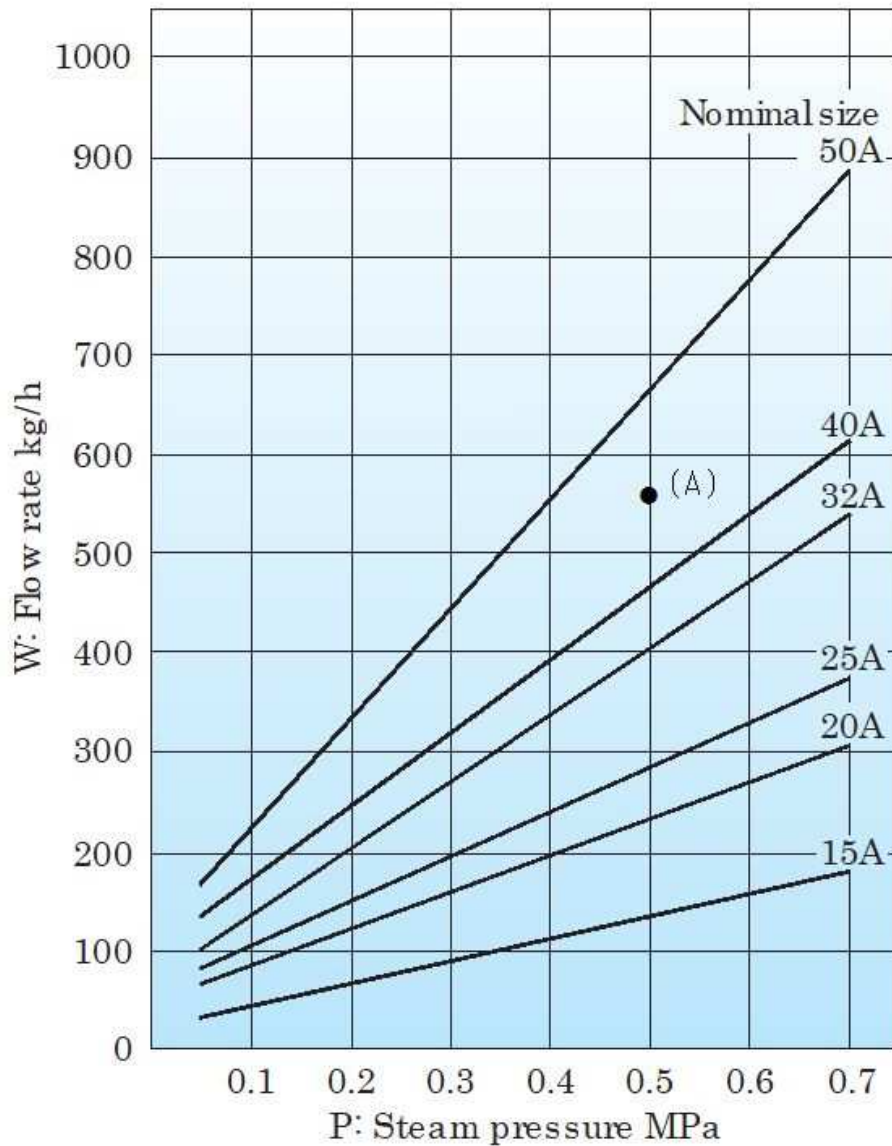

- Formula for calculating the required nominal size

The steam volume “W” required to raise the temperature of “Q” amount of water by “B” degrees Celsius in “A” amount of time is calculated as follows:

$$w = \frac{B \times Q}{500 \times A}$$

W:Steam volume(kg/h)  
 Q:Water volume(kg)  
 B:Desired Temp.rise(°C)  
 A:Desired time(h)

Based on the steam volume (W kg/h) and steam pressure(P MPa)values obtained by the above formula,the appropriate nominal size is selected using the “Nominal Size Selection Chart”.

●Nominal size calculation example

When the temperature of 7000kg of water is to be raised from 20 to 60°C over a period of 1 hour, with a steam pressure of 0.5MPa, the nominal size is calculated as follows:

$$w = \frac{(60 - 20) \times 7000}{500 \times 1} = 560 \text{ (kg/h)}$$

Referring to the “Nominal Selection” chart, find point (A) where the 0.5MPa (pressure) and the 560 (flow rate) lines intersect. As point (A) is between the 40A and 50A sizes, the larger size of 50A is selected.

4. Noise characteristics charts

- Steam Pressure : 0.3MPa

Nominal Size 15A~25A

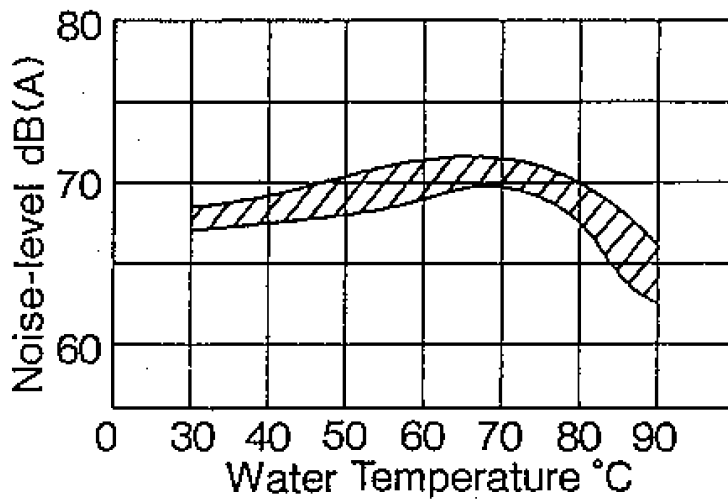

Nominal Size 32A~50A

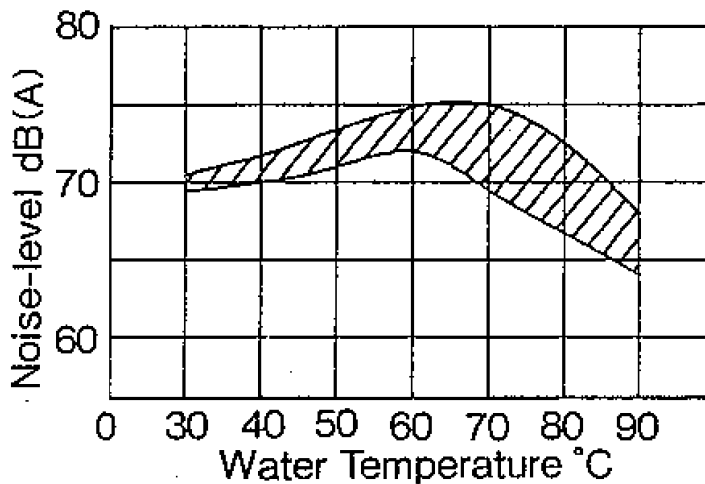

●Steam Pressure : 0.5MPa

### Nominal Size15A~25A

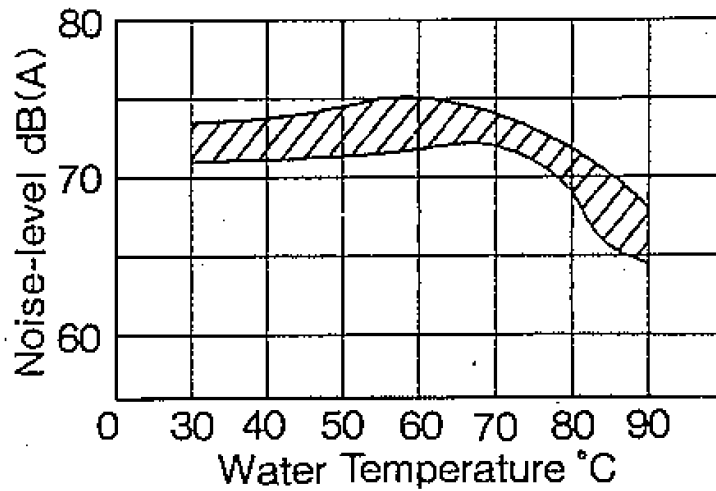

### Nominal Size32A~50A

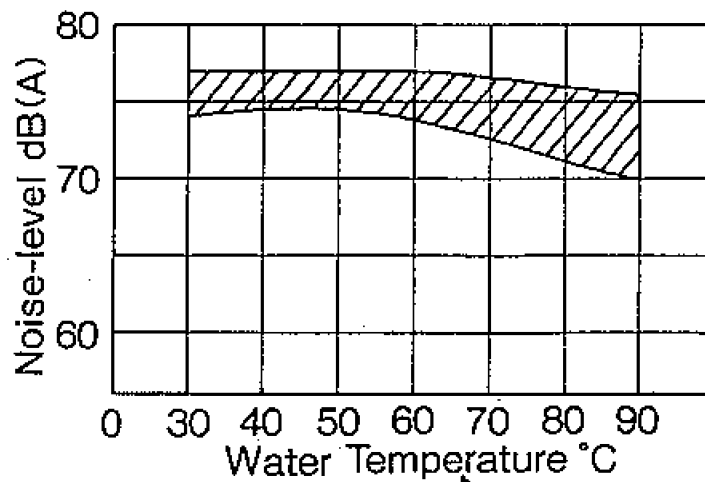

\*The noise characteristics indicated in the above charts may vary somewhat depending on the tank size and shape, and on the noiseless heater's mount position, etc.

\*Noise is measured at a point 1 meter above the waterline.

## 5. Installation and operation

### 5.1 Precautions for installation

#### ⚠ Caution

- (1) The noiseless heater should be mounted 300mm or more from the tank's walls and bottom. (Refer to 5.2 Example of piping)
  - \* Vibration may occur in a tank by the flow of a liquid.
- (2) Use it within the maximum warning sound temperature limit.
  - \* Vibration in a tank and piping occurs.

- (1) In order to obtain a result as planned, please fully utilize the nominal size selection chart.
- (2) There are various methods in attachment and please take into consideration the blow-off position with the size of a tank etc. (Refer to 5.2 Example of piping)
- (3) VB-7 vacuum relief valve is recommended in the piping in order to prevent a back-flow condition when the steam is stopped.

### 5.2 Example of piping

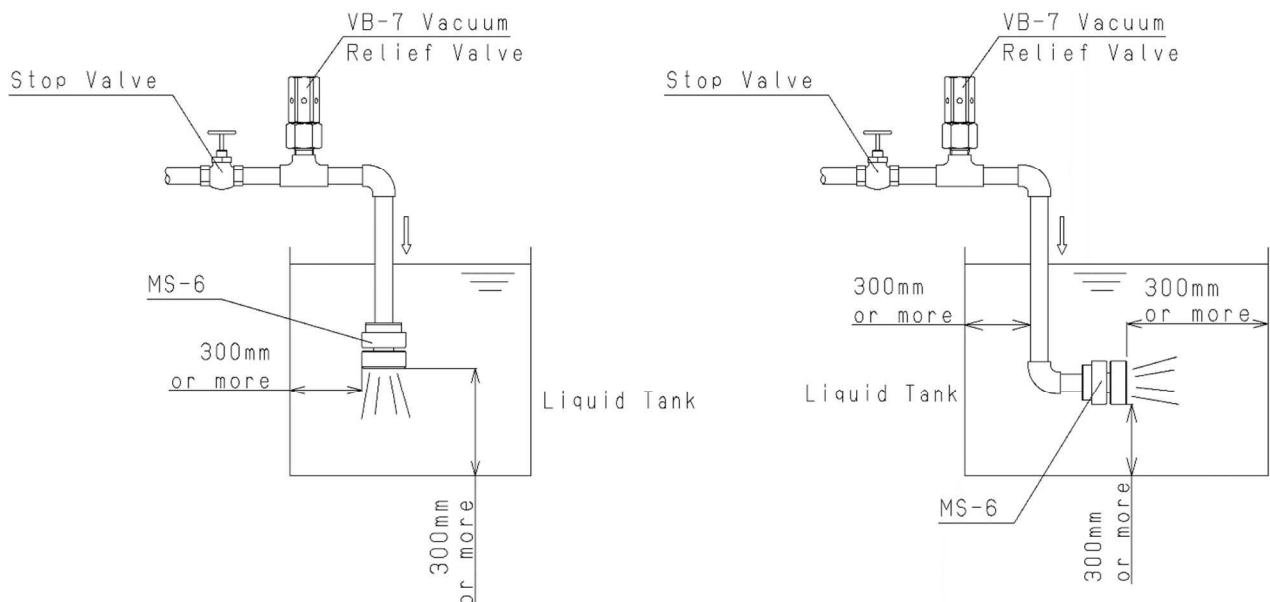

### 5.3. Precautions for operation

#### ⚠ Warning

- (1) Do not touch the product by bare hands
  - \* Failure to follow this notice may cause burn or injury.
- (2) Submerge the product in the tank.
  - \* Steam may spout out and result in burns.