

MODEL SCV-2 CHECK VALVE PRODUCT MANUAL

Thank you very much for choosing the Yoshitake's product. To ensure the correct and safe use of the product, please read this manual before use. This manual shall be kept with care for future references. The symbols used in this manual have the following meanings.



 Warning	This symbol indicates a potentially hazardous situation that, if not avoided, could result in death or serious injury.
 Caution	This symbol indicates a hazardous situation that, if not avoided, may result in minor or moderate injury or may result in only property damage.

Table of Contents

1. Usage of the Product	1
2. Specifications	1
3. Dimensions and Weights	1
4. Pressure loss	2
5. Installation	
5.1 Precaution for installation	2
6. Operation procedure	
6.1 Precaution for operation	3
7. Maintenance	
7.1 Troubleshooting	3
7.2 Warning for maintenance	3
7.3 Disassembly	3
7.4 Assembly	3~4
7.5 Exploded view	4
Warranty Information	

YOSHITAKE

1. Usage of the Product

The SCV-2 check valve prevents backflow of fluid. It is widely used in steam pipelines or cold and hot water pipelines.

2. Specifications

Model	SCV-2
Nominal size	15A, 20A, 25A, 40A, 50A
Application	Steam, Cold and hot water
Maximum pressure	1.6 MPa
Applicable temperature	5 to 220 °C
Connection	JIS Rc screwed
Minimum valve opening pressure	0.003 MPa

* Since a small amount of fluid leaks out of the product, it cannot be used for applications requiring complete closing.



Caution

Please confirm that the indications on the product correspond with the specifications of the ordered product model before use.

* If they are different, do not use the product and contact us.

3. Dimensions and Weights

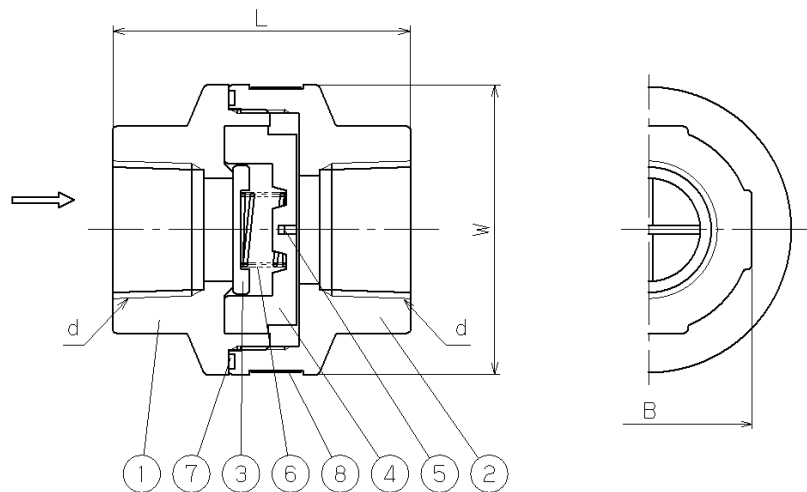

No.	Part name
1	Body
2	Cover
3	Disc
4	Retainer A
5	Retainer B
6	Spring
7	Gasket
8	Plate

Nominal size	Connection d	(mm)				Weight (kg)
		L	W	B		
15A	JIS Rc 1/2	57	50	34	0.5	
20A	JIS Rc 3/4	57	50	34	0.45	
25A	JIS Rc 1	72	69	50	1.1	
40A	JIS Rc 1 1/2	88	89	67	2.0	
50A	JIS Rc 2	88	89	67	1.5	

Fig.1 Dimensions and weights

4. Pressure loss

Fluid: water

Fig. 2 Pressure loss chart

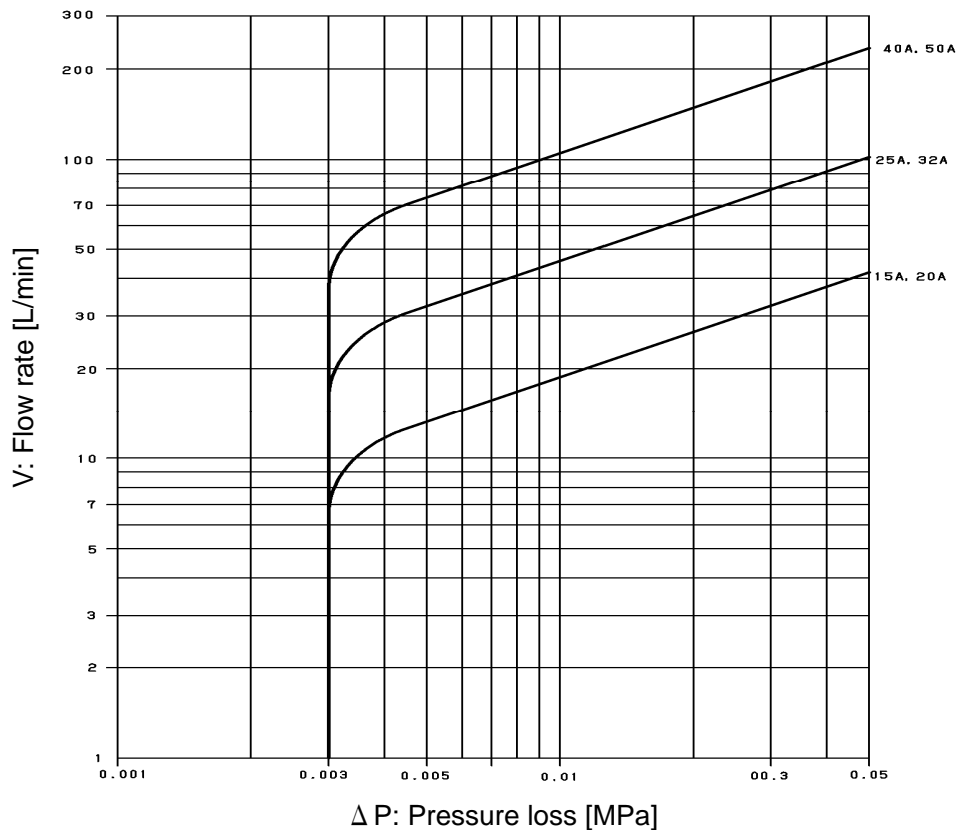

5. Installation

5.1 Precaution for installation

⚠ Caution

1. Before installing the product in the piping, be sure to remove foreign substances and scale from the piping.
* Failure to follow this notice may prevent the product from functioning properly due to the ingress of foreign substances and scale into the product.
2. At installation, check the direction of the product so that the fluid flowing and the arrow marked on the product are in the same direction.
* Wrong direction prevents the product from functioning properly.
3. Connect the product to the piping so that excessive load, torque or vibration cannot be applied to the product. Be sure to connect the product to piping firmly.
* Failure to follow this notice may cause fluid leakage and result in burns or property damage.
4. When installing the product to steam piping, do not apply seal agent for ambient temperature to screwed part of pipes (Use seal tape made of fluororesin etc.)
* Use of seal agent for ambient temperature may attach it to valve part and lead to valve leakage.
5. Keeping fluid in the product for a long term fixes sliding parts and leads to malfunction of the product.
6. Fluid with adhesiveness makes the parts stuck and leads to malfunction of the product.
7. Performance value of each Nominal Size Selection Chart is referential value. Since it can change according to piping condition and usage environment, secure safety factor of 20% or more for performance value when selecting products.
8. Consider usage condition (usage frequency or durability) when selecting products.
9. Any installation posture (vertical or horizontal) is possible.
10. Installation of rapid open close valve at the outlet side of the product may lead to shorten service life of the product.

6. Operating procedure

6.1 Precaution for operation

Warning

Before leading fluid, make sure that there is no danger when the fluid flows to the end of piping.

* If tightening is not secured, hot fluid may spout out and result in burns.

* Fluid outflow may cause property damage.

7. Maintenance

7.1 Troubleshooting

Trouble	Cause	Remedy
Fluid does not flow.	1. Contact surface of body [1] and disc [3] is stuck.	1. Disassemble and clean.
	2. Installation direction is wrong.	2. Install the product correctly.
Fluid flows back.	1. Foreign substance is attached to contact surface of body [1] and disc [3].	1. Disassemble and clean.
	2. Contact surface of body [1] and disc [3] is worn away.	2. Replace with new ones.
	3. Internal parts are broken.	3. Replace with new ones
Outside leakage	1. Gasket [7] is broken.	1. Replace the gasket [7].

7.2 Warning for maintenance

Warning

Completely discharge the pressure inside of the product, line and equipment before disassembling or maintenance. In the case of high-temperature fluid, cool down the product till it can be touched with bare hands.

* Failure to follow this notice may result in injury or burns.

7.3 Disassembly

1. Remove body [1] and cover [2].
2. Remove retainer B [5] and retainer A [4] in this order (if they are tightly fastened, use tools such as plier).
3. Remove spring [6] and disc [3] in this order (all the internal parts are removed).
4. Remove the gasket [7] from cover [2].
5. After the disassembly, clean the parts with compressed air or detergent.

7.4 Assembly

Caution

1. At assembly, be sure to replace the gasket [7] with new one.

* Failure to follow this notice may result in leakage, burns or property damage.

2. Clean the contact surface of the gasket [7] for the body [1] and cover [2].

* Poor cleaning may lead to leakage of fluid from the gasket, and result in leakage, burns or property damage.

3. Connect the parts firmly (pay attention to direction of the disc [3]).

* Failure to follow this notice may lead to deformation or breakage of the parts.

4. At assembly, see “7.5 Exploded view” and assemble the parts in the reversed order of “7.3 Disassembly”.

Nominal size	Torque for tightening cover
15A, 20A	150 N·m
25A	200 N·m
40A, 50A	250 N·m

7.5 Exploded view

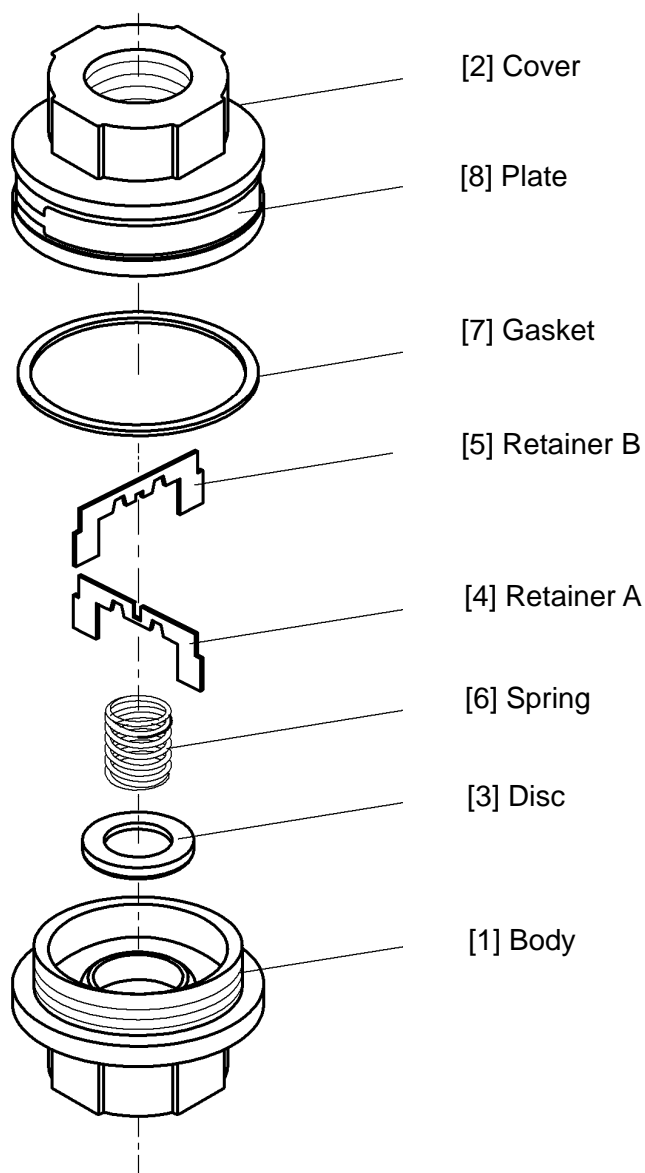

Fig. 3 Exploded vie