

④ SIZE: 40A~50A

5	Gasket	Non-Asbestos	ガスケット	Non-Asbestos	1
4	Plug	Carbon Steel or Malleable Cast Iron	プラグ	S15C or FCMB310	1
3	Screen	Stainless Steel	スクリーン	SUS304	1
2	Cap	Ductile Cast Iron	キャップ	FCD450	1
1	Body	Ductile Cast Iron	本体	FCD450	1
No.	Name of Parts	Material	部品名	材質	Q.TY

(mm)

Size	L	H1	d	Screen		Flange JIS 10K FF				Ø Plug	Weight (kg)
				ds	ls	D	C	t	n-h		
15A	130	61	15	22	40	95	70	16	4-15	—	1.9
20A	140	75	20	27	56	100	75	16	4-15	—	2.5
25A	160	88	25	34	66	125	90	18	4-19	—	4.0
32A	175	104	35	43	76	135	100	20	4-19	—	5.2
40A	190	115	40	50	85	140	105	20	4-19	R 1/2	6.7
50A	225	140	50	61	107	155	120	20	4-19	R 1/2	10.2

Specification	
Fluid	
Press.	MPa
Temp.	℃
Flow Rate	
Inside Screen	Mesh
Outside Screen	Ø - ㏄/cm ²

TYPE SY-40 STRAINER
ストレーナ

Approval	M. KUME
Check	M. YOSHIDA
Drawing	h. OKUMURA
Drawing No.	Y-958-2105-2B
Date	8 DEC. 2011



*フランジ厚みは規格より厚くなっております。
*Thickness of Flange thicker than standard type

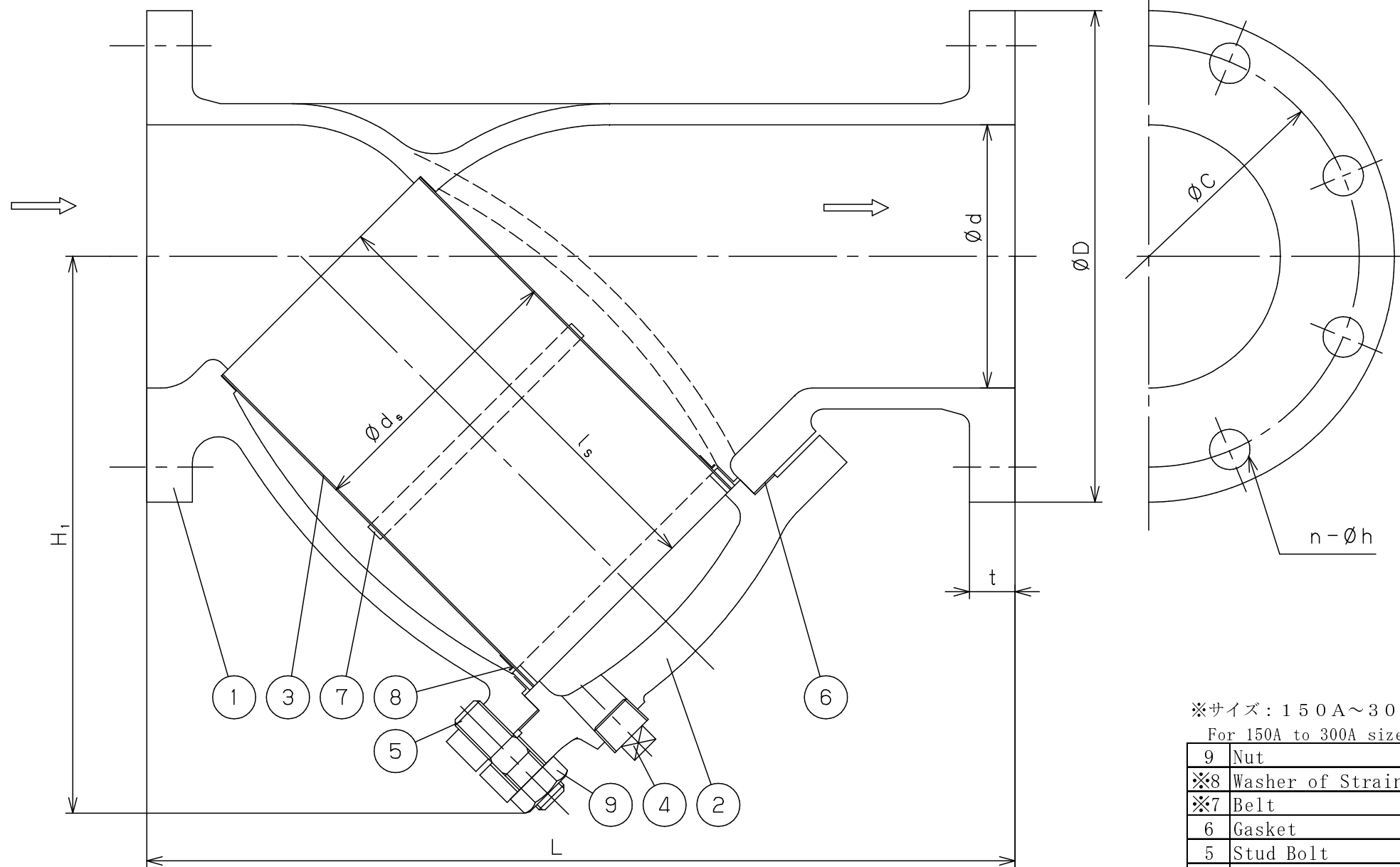

※サイズ：150A～300Aは、⑦帯鋼、100A～300Aは⑧ストレーナ受が付きます。

For 150A to 300A sizes, with ⑦Belt, For 100A to 300A sizes, with ⑧Washer of Strainer.

No.	Name of Parts	Material	部品名	材質	Q.TY
9	Nut	Rolled Steel	ナット	SS400	1set
※8	Washer of Strainer	Stainless Steel	ストレーナ受	SUS304	2
※7	Belt	Stainless Steel	帯鋼	SUS304	2or3
6	Gasket	Non-Asbestos	ガスケット	Non-Asbestos	1
5	Stud Bolt	Rolled Steel	植込みボルト	SS400	1set
4	Plug	Carbon Steel or Malleable Cast Iron	プラグ	S15C or FCMB310	1
3	Screen	Stainless Steel	スクリーン	SUS304	1
2	Cover	Ductile Cast Iron	ふた	FCD450	1
1	Body	Ductile Cast Iron	本体	FCD450	1

Size	L	H1	Screen			Flange JIS 10K FF					⑤ Stud Bolt	④ Plug	Weight (kg)
			ds	ls	d	D	C	t	n-h				
65A	255	167	73	125	65	175	140	22	4-19	4×M12	R 1/2	14.5	
80A	330	190	88	130	80	185	150	22	8-19	4×M16	R 1/2	18.3	
100A	370	225	108	180	100	210	175	24	8-19	6×M16	R 3/4	29.7	
125A	415	263	136	200	125	250	210	24	8-23	8×M16	R 3/4	40.5	
150A	495	315	160	250	150	280	240	26	8-23	8×M20	R 3/4	66.0	
200A	565	385	210	300	200	330	290	26	12-23	10×M20	R 3/4	95.8	
250A	690	460	260	370	250	400	355	30	12-25	10×M20	R 3/4	167.5	
300A	840	556	315	442	300	445	400	32	16-25	12×M22	R 3/4	286.0	

*フランジ厚みは規格より厚くなっております。
*Thickness of Flange thicker than standard type

Specification	
Fluid	
Press.	MPa
Temp.	℃
Flow Rate	
Inside Screen	Mesh
Outside Screen	φ - ケ/cm ²

TYPE SY-40 STRAINER ストレーナ

Approval	T. Nishiyama
Check	N. Yabutani
Drawing	T. Tsubuku
Drawing No.	Y-0958-2105
Date	28 AUG. 2005

